

Designing a pervasive chess game

André Pereira, Carlos Martinho, Iolanda Leite, Rui Prada,
Ana Paiva

Instituto Superior Técnico – Technical University of Lisbon and INESC-ID,
AV. Professor Cavaco Silva – Taguspark
2780-990 Porto Salvo, Portugal
{Andre.Pereira, Carlos.Martinho, Iolanda.Leite, Rui Prada}@tagus.ist.utl.pt,
Ana.Paiva@inesc-id.pt

Abstract. Chess is an ancient and widely popular tabletop game. For more than 1500 years of history chess has survived every civilization it has touched. One of its heirs, computerized chess, was one of the first artificial intelligence research areas and was highly important for the development of A.I. throughout the twentieth-century. This change of paradigm between a tabletop and a computerized game has its ups and downs. Computation can be used, for example, to simulate opponents in a virtual scenario, but the real essence of chess in which two human opponents battle face-to-face in that familiar black and white chessboard is lost. Usually, computer chess research focuses on improving the effectiveness of chess algorithms. This research, on the other hand, focuses on trying to bring back the essence of real world chess to a computerized scenario. To achieve this goal, in this paper we describe a model inspired by the field of Pervasive Gaming, a field that profits by the mix of real, virtual and social game elements.

Keywords: Chess, Pervasive Gaming, Tangible User Interfaces, Graphical User Interfaces, Design Model, Agents.

1 Introduction

“Pervasive gaming brings computer entertainment back to the real world” [14] and by doing so overcomes some restrictions of conventional computer games. Players no longer have to be tied to computer screens and human computer interaction is not constrained by graphical user interfaces. Recently, successful controllers designed to employ user’s body movements in the real world as a game input mechanism started to appear, such as the Nintendo Wii’s controller [19] or the Guitar Hero peripheral [1]. Games using this type of controllers increase the social interaction between users, their individual engagement and appeal to wider markets [22]. These booming gaming experiences are based in concepts of pervasive gaming. We believe that the design of digital adaptations of traditional board games such as chess can also benefit from those same concepts.

Past research suggests that chess helps any person to develop exact methods of thinking. It was shown that children that received systematic instructions in chess improved their school efficiency in different subjects [13], making chess particularly useful when practiced in early school days, since most children prefer to learn something while playing rather than to learn it formally. Computerized chess helps to spread the same positive effects of traditional chess instructions while surpassing the original game by allowing among other things to play at any time against digital opponents of custom strength. However, not everything in computerized chess is positive. The social possibilities of the game, in which both opposing players are able to interact becomes limited since we cannot see hesitation or any expressed emotion on our opponent's "face".

Taking advantage of both computerized chess and traditional chess game elements, it would be interesting to maintain the playing experience as close as possible to that of traditional chess, where opponents face each other and play on a physical chessboard. Inspired by the field of pervasive gaming, the work presented on this paper aims at restoring such aspects of the chess playing experiences.

In the next section, we show a brief literature review that follows the evolution of chess playing machines and computerized chess throughout time. Then we establish a concept of a design model that pursues the goal of designing single player pervasive chess games. The fourth section describes an application featuring a social robot and a tangible user interface that was built using our established model. Section 5 briefly introduces the experiments we conducted with our application and some results are presented. Finally, in the last section, we draw some conclusions and directions for future work.

2 Related Work

In the eighteen century the idea of creating a chess playing machine arose with The Turk [11], a fake chess automaton that became famous before it was exposed as a fake. It was basically a mechanical illusion created by hiding a person with high chess knowledge inside the machine who would operate it. Only in 1912 did a real automaton appeared under the name of "El Ajedrecista" [24]. It used electromagnets under the board and automatically played a three chess piece endgame by moving a King and a Rook, against the human opponent. In the late 1940s, the field of mechanical chess research faded as first computers appeared. Since then, computerized chess became an important research subject: if a computer could play chess, then other problems that require human intelligence could also be solved. In less than fifty years, chess programming evolved to the point that a chess engine (Deep Blue) could beat the best human player in the world at that time [6] (Kasparov).

Most of the nowadays chess applications use a chess engine as the "thinking" part of the program and a Graphical User Interface (GUI) as its interface. One of the most popular and used GUIs is Tim Mann's freeware Winboard [16]. This interface allows users to visualise and interact with a virtual chessboard by using a mouse. Still there are some problems with this kind of interfaces. Namely, to operate them we need to

pull away from the original experience in which we face a real chessboard and can change the state of the game simply by moving a piece on the board. To address this limitation some research projects have used Tangible User Interfaces (TUI) in its design. TUIs “are a growing space of interfaces in which physical objects play a central role as both physical representations and controls for digital information” [23]. A broad discussion of TUI has been provided by Ullmer and Ishii [23].

The Chesster [18] interface to computerized chess is an example of a chess research project that uses a TUI. It consists in a robotic arm with pincers that is used to move the pieces around the chess board. It can be used to play against a computer or a geographically remote opponent. Chesster has a robotic arm and thus has the advantage of making the computer’s move, but has the disadvantages of doing it very slowly, being expensive and invading a lot of space. A low cost home made solution, the ChessBox system [12] is built by using a wooden box to contain a webcam, a mirror and two inexpensive glass chess sets. The mirror is used to reflect the image of the chessboard back to the camera which tracks the pieces. However this system suffers from vision system’s limitations such as poor light conditions and moves are not always recognized. A more effective chess TUI was built by DGT Projects [4], a commercial electronic board that looks like any standard chess set with a standard set of pieces. When using this board with compatible software, moving a physical piece on the chessboard moves the same virtual piece on the application.

3 Design Model

In this section we intend to put together the advantages of both real world and computerized chess, and inherently remove their drawbacks. We will begin by building two models. One reflects upon the design of the original chess game and the other one depicts its computerized version. Inspired by the related work shown in the previous section and by the field of pervasive gaming we then present a model for designing pervasive chess games.

The following models will be built using three domains defined by Magerkurth [15]: physical, social and virtual. By analysing game elements of chess in these domains we can try to join them, shifting chess towards the paradigm of pervasive gaming.

The *physical* domain lies in the world around us. Gaming elements in this world generally stand for tangible user interfaces. In the physical domain everyday life properties can be used in a game. For instance, we can take information from the weather outside our window and use that data to change the virtual world accordingly. In the *social* domain face to face interactions generally occur. It includes ingredients such as directed speech and gestures, or the abilities of showing and capturing emotions. In social experiences players interact in a natural fashion, therefore making the experience more instinctive and socially rewarding. The last domain, *virtual*, is the typically used environment in nowadays gaming. Any game involving a computerized scenario has a virtual domain, where the digital game logic is displayed usually by a GUI.

3.1 Model for a traditional chess game

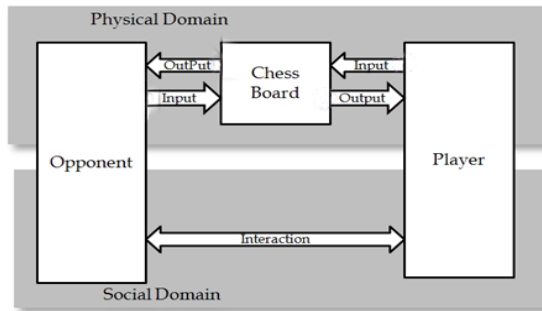

Fig. 1. Design model for a tradition chess game

Playing chess in its original form with a real chessboard and against a real opponent share the social advantages, physical controls and information offered by most of board games. **Fig. 1** shows the design model for a regular chess game between two players. The human-to-human interaction present in a traditional chess game has elements from the physical and social domains as integral parts of the gaming experience. An example of social interaction in a chess game happens when we try to understand our opponent's "mind" by, for instance, detecting that false signal he just made that expresses a terrible mistake with the intention of bluffing. Both players are in the physical domain where they interact with a physical chessboard. Since the chessboard is shared by both players, when a player inputs a new move, that move becomes the output of his adversary.

3.2 Model for a single player computerized chess game

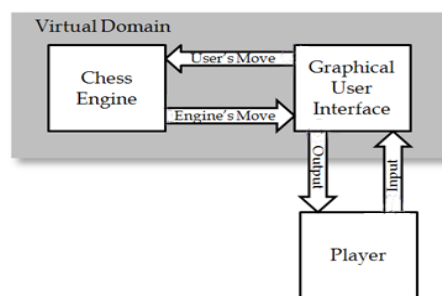

Fig. 2 Design model for most of single player computerized chess games

The computerized chess model in **Fig. 2** contain the usual chess engine and GUI mentioned in the related work section.

The human player belongs to the physical domain. However, since there is no interaction in that domain in this particular model, we chose not to represent it. The virtual domain, on the other hand, is where all the interaction takes place.

The term opponent does not appear in this model because even though there is a chess engine that “thinks” about the best move to make, the embodiment of such opponent is usually not physically or virtually represented.

The lack of social interaction between opposing players is one of the main disadvantages of computerized chess. On the other hand, the digital version of chess allows us to play at any time with an opponent of custom difficulty. Also, computerized chess allows new features that were only possible by consulting chess instructors or chess books such as move advices or consult database of famous games.

3.3 Model for a pervasive chess game

In 2005 Magerkurth et al. [14] categorized pervasive games in 5 different genres: computer augmented tabletop games, affective games, smart toys, location-aware games and augmented reality games.

Computer augmented tabletop games gives us the best of two worlds: the interaction and communication between the players who sit around the same table, facing each other at an intimate distance; and the computing support that can for example be used to create virtual game opponents, to relieve players of mundane tasks or to enhance the game with visual and audio effects. *Affective games* are games that take advantage of emotional design for instance to display emotions through a physically or virtually embodied character. Also, games that capture how a player is feeling at a given moment and integrate that personal information in the gaming context can be considered affective games. *Smart toys* take advantages of two worlds by integrating the power of computers and electronic chips with traditional toys. The shape of a toy suggests the way it should be played, but contrary to games, they are not bound by rules or limitations [5]. *Location-aware games* use the world we live in as a game board, and can make objects and body movements as an integrating part of our digital games. *Augmented Reality* is a technology that brings virtual objects into the real world. This form of environment provides more enhanced immersion by seamless merging of real and virtual worlds.

Our pervasive game model fits into the first two genres. We want a model that reflects a computer augmented tabletop game, since we still want to use a physical chessboard but with the computing support that normally only exists in computerized chess games. Chess TUIs that already did this were presented in the related work section. The real innovation behind our model was inspired by the affective games genre. Using this genre we can easily imagine having a robot like Leonardo [3] as our opponent. Combining these two genres we show in **Fig. 3** our pervasive model which contains the virtual domain derived from computer chess, and both the physical and social domains from the traditional tabletop chess game.

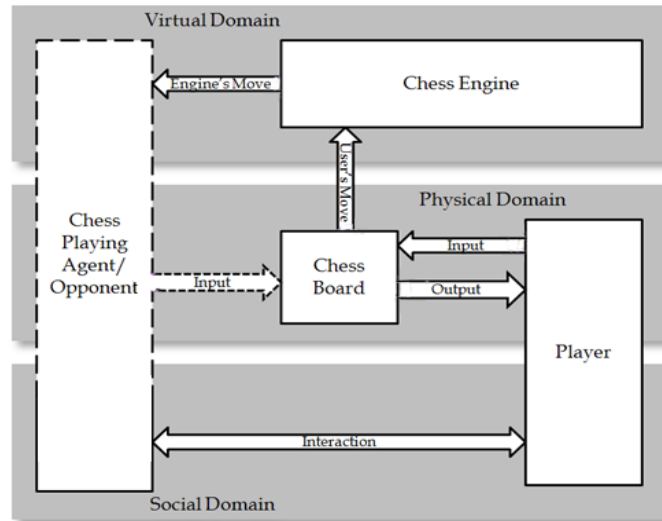

Fig. 3. Our design model for a single player pervasive chess game

Our model uses a social agent that interacts with the user of a computer augmented chess game. An agent is an artificial software system situated in a computerized environment, which senses that environment and acts on it, over time, achieving its goals [20]. The idea is to simulate the social interaction between two human players by having a human-agent relationship. For instance, while waiting for the opponent's move, the player can try to interpret the agent's "mind", or even look at its defeated expression when it loses. The chess playing agent/opponent appears in a dashed line across the virtual and physical domains because it can be physically (e.g., a robot) or virtually embodied (e.g., a graphical avatar).

When comparing the virtual domain of this model to the one of computerized chess, it loses the GUI to display the virtual chessboard since now we have a chess TUI in the physical domain to replace it. While using a tangible user interface, we can input the user's move into the virtual domain simply by moving a piece in the chessboard. The agent may have the capability of moving its pieces with, for example, a mechanical arm. If so, he plays the move, otherwise the agent must ask the player to make its move.

Although not represented in this model, a GUI might be also included to display a virtually embodied opponent and data such as tips and advices. The objective of the chess engine is the same, which is to provide a single player mode and all the advantages implicit in computerized chess.

4 Application

In the previous section, a design model for a pervasive chess game was presented. Following that model, we developed an application named "iCat, the Chess Player".

In this application the user plays against a social robot on an electronic chessboard that automatically detects the user's moves. Our application can begin from the initial chess position or from any valid position (e.g. a chess problem). The user can take hints about the state of the game by analyzing the agent's facial expressions. After each user's move, the agent gives feedback about that move. If it is an invalid move he uses pre-made animations or text-to-speech with lip sync to warn the user of its error. If the user plays a valid move, for instance a bad one, iCat will react with a happy animation. When this happens the user can take it back and play another move. By repeating this process, chess can be learned by distinguishing the bad moves from the good ones. The emotion system we used for controlling the agent's emotional behaviour is based on anticipatory mechanisms [17] and is fully described in our previous work [9].

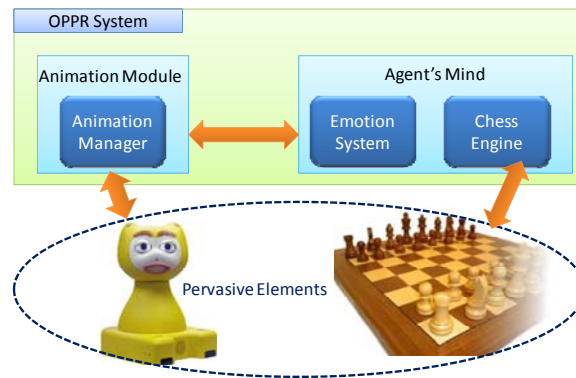

Fig. 4. iCat, the chess player application

The pervasive elements in this game are the physical components that allow us to bring the social and physical domains to a computerized chess game (see **Fig. 4**). We had to choose the technology for the pervasive elements which are the chess playing agent's embodiment and the chess TUI.

The chess playing agent for this scenario should have the ability of displaying its emotional behaviour to the user, in order to increase the social interaction during the game. The selected embodiment was a user-interface robot developed by Phillips Research [2] named iCat, which is capable of mechanically rendering facial expressions. The iCat can be considered a social robot since it has many of the characteristics needed to simulate human-to-human interaction. Therefore we think it was an accurate choice to embody our social chess playing agent. The only problem with iCat was not having any mechanism that allows it to physically move the chess pieces, so it asks the user to play its move on the chessboard.

Our choice for the chessboard was a TUI, the Electronic Chessboard from DGT Projects. As we did not need a grandmaster level opponent (because the focus was to create a pervasive chess game). We chose Tom Kerrigan's Simple Chess Program [8] as the chess engine.

More technical and detailed information on how we integrated all these components can be found in [21].

5 Evaluation

Two experiments (described in [10]) were conducted to evaluate the implementation of our pervasive chess game. The results from the first experiment indicated that a chess playing agent with emotional behaviour can better perform the task of helping users to understand a gaming situation (than a simple agent without emotional behaviour). The second experiment pointed that user's enjoyment is higher when users are interacting with this application using the described robotic agent, when compared to an identical version with a screen based version of the same agent. The robotic scenario had a more immersive user experience, an improved feedback and a more believable social interaction. This is due to the fact that the more pervasive experience that used the robotic character had a higher feeling of social presence, which usually results in more positive evaluations [7].

We have also made a qualitative evaluation by asking 18 amateur chess players with previous experience in computerized chess if they prefer playing in our application or with their usual chess software. We used a 5 point Likert scale. Table 1 depicts the results.

Table 1. Results from the qualitative evaluation.

Strongly Disagrees	Disagrees	Undecided	Agrees	Strongly Agrees
0	0	4	5	9

By looking at these results and by watching people interact with our application in various demonstrations we believe that a pervasive chess application would be successfully accepted by most of the chess community, especially with children.

6 Conclusions

The main contribution of this work was creating a design model for a pervasive chess game. Inspired by pervasive gaming, the model combined the social and physical domains of a traditional chess game, with the virtual domain of a single player computer chess game. We used this model to implement an application named "iCat, the Chess Player". The results of two experiments built upon this application suggested that: (1) user's understanding of the game state increased when they were observing the agent's emotional expressions, (2) participants had more fun with the more pervasive version of our game which uses a robotic agent than those that played against a similar version with a virtual opponent in a GUI. Further, a qualitative evaluation suggested that participants preferred our application over their usual chess

software. These results make us consider that hybrid chess games based on this model would be successfully accepted by a wide range of people.

By researching the field of pervasive gaming we looked for ways in which we could bring computerized chess back to the real world. We found them by exploring two genres of pervasive gaming: computer augmented tabletop games and affective games. However the other genres of pervasive gaming can also inspire us to create other innovative gaming experiences. For future work we intend to explore some of these possibilities not only in chess but also in other tabletop games.

References

1. Activision. Guitar Hero. [cited 18/01/2007]; Available from: <http://www.guitarhero.com/>.
2. Breemen, A. Animation Engine for Believable Interactive User-Interface Robots. in IEEE/RSJ International Conference on Intelligent Robots and Systems. 2004. Sendai, Japan.
3. Brooks, A., et al., Robot's Play: Interactive Games with Sociable Machines Computers in Entertainment, 2004. 2: p. 1-18.
4. DGT. DGT Projects. 2007 [cited 18/09/2008]; Available from: <http://www.dgtprojects.com/>
5. Herman D'Hooge, L.D., Smart Toys: Brave New World?, in Conference on Human factors in computing systems (CHI 2000). 2000: Hague, Netherlands.
6. IBM. IBM Research Deep Blue Overview 1997 [cited 18/01/2007]; Available from: <http://www.research.ibm.com/deepblue/watch/html/c.shtml>.
7. Jung, Y. and K. Lee. Effects of physical embodiment on social presence of social robots. in Seventh Annual International Workshop PRESENCE 2004. 2004. Valencia, Spain Polytechnic Universtiy of Valencia.
8. Kerrigan's, T. Tom Kerrigan's Home Page. 2007 [cited 18/01/2007]; Available from: <http://home.comcast.net/~tckerrigan/>.
9. Leite, I., et al., iCat: an affective game buddy based on anticipatory mechanisms, in Proceedings of the 7th international joint conference on Autonomous agents and multiagent systems - Volume 3. 2008, International Foundation for Autonomous Agents and Multiagent Systems: Estoril, Portugal.
10. Leite, I., et al. Are emotional robots more fun to play with? in Robot and Human Interactive Communication RO-MAN 2008. 2008. Munich, Germany.
11. Levitt, G.M., ed. The Turk, Chess Automaton. 2000, McFarland.
12. Lewis, C. and S. Sallam, ChessBox: A Tangible Interface for Computer Chess. University of Saskatchewan, Canada. 2004.
13. Linder, I., Chess, a Subject Taught at School, in Sputnik: Digest of the Soviet Press, June 1990. p. 164-166.
14. Magerkurth, C., et al., Pervasive games: Bringing computer entertainment back to the real world. ACM Computers in Entertainment, 2005. 3, n° 3.
15. Magerkurth, C., T. Engelke, and M. Memisoglu. Augmenting the virtual domain with physical and social elements: towards a paradigm shift in computer entertainment technology. in ACM SIGCHI International Conference on Advances in computer entertainment technology. 2004.
16. Mann, T. Tim Mann's Chess Pages. 2007 [cited 18/09/2008]; Available from: <http://www.tim-mann.org/xboard.html>.
17. Martinho, C. and A. Paiva. Using Anticipation to Create Believable Behaviour. in Proceedings of the 21st National Conference on Artificial Intelligence and the 18th Innovative Applications of Artificial Intelligence Conference. 2006. Stanford, California, USA: AAAI Press.

18. Meppelink, D. and F. Martin, A Tangible Interface to Computerized Chess. 2003, University of Massachusetts Lowell.
19. Nintendo. Nintendo Wii. [cited 18/01/2007]; Available from: <http://wii.com/>.
20. Nwana, H.S., Software Agents: An Overview. Knowledge Engineering Review, 1996. 11(3): p. 1-40.
21. Pereira, A., et al., iCat, the chess player: the influence of embodiment in the enjoyment of a game, in Proceedings of the 7th international joint conference on Autonomous agents and multiagent systems - Volume 3. 2008, International Foundation for Autonomous Agents and Multiagent Systems: Estoril, Portugal.
22. Si, et al., Stirring up experience through movement in game play: effects on engagement and social behaviour, in Proceeding of the twenty-sixth annual SIGCHI conference on Human factors in computing systems. 2008, ACM: Florence, Italy.
23. Ullmer, B. and H. Ishii, Emerging frameworks for tangible user interfaces. IBM Systems Journal, 2000. 39 n° 3: p. 915-931.
24. Wikipedia. Wikipedia - El Ajedrecista. 2007 [cited 18/09/2008]; Available from: http://en.wikipedia.org/wiki/El_Ajedrecista.